

**VHM-Gravierfräser Z2**  
Solid Carbide Grooving and Engraving Cutter Z2

**7601**

D	I	L	∠	S	Best.-Nr./Part No.	Euro
8	7	70	60°	8	7601.080.80	79,00

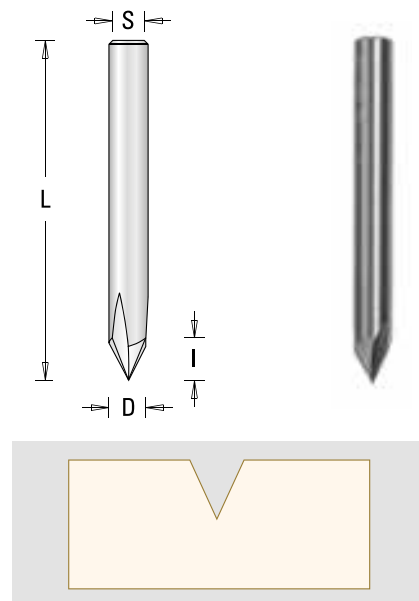

**HW-V-Nutfräser Z2**  
V Groove Bit Z2

**7605**

D	I	L	∠	S	Best.-Nr./Part No.	Euro
16	12,7	41,3	90°	6	7605.160Z60	53,50
9,5	11	45	90°	8	7605.095Z80	33,50
12,7	16	47,5	60°	8	7605.127Z80	34,00
12,7	12,7	44	90°	8	7605.129Z80	34,00
16	12,7	45	90°	8	7605.160Z80	53,50
19,1	16	48	90°	8	7605.191Z80	58,00
25,4	19,1	51	90°	8	7605.254Z80	64,00
25,4	19,1	57	90°	12	7605.254Z12	64,00
31,8	25,4	63,5	90°	12	7605.318Z12	80,00
38,1	31,8	70	90°	12	7605.381Z12	89,00
51	44,5	83	90°	12	7605.510Z12	197,50

